

E2-EMAFY40-170

40W EMERGENCY DRIVER

NEW

Self-Test:

The emergency LED driver contains a control/monitor circuit which will perform a 30-second discharge test once a month and a fully discharge test once a year. At this time, the unit will simulate an AC power failure and automatically switch to emergency mode. During routine testing, the unit will monitor the operation of the LED load, battery voltage and emergency duration. If the unit detects any problems, the indicator will flash quickly.

Indicator Light:

- AC operation, indicator light will keep on.
- Emergency operation, indicator light will flash slowly (light will turn on for 2 seconds, light will turn off for 2 seconds).
- In a failure, indicator light will flash quickly (light will turn on for 0.2 seconds and off for 0.2 seconds).

Test Switch:

- In AC operation, press the test button for 30 seconds emergency test.
- In AC operation, press the test button twice within 2 seconds, until emergency battery is fully discharged.
- In emergency operation, press the test button once, this will turn off both the emergency, the lamp and indicator light will go out at the same time.

PRODUCT DESCRIPTION:

E2 Lighting's 40W emergency driver, enables normal and emergency operation that can maintain illumination of an LED fixture for a minimum of 90 minutes in the event of a power loss. When AC power is restored, the driver automatically returns to charging mode. Also includes a test button and button installation faceplate.

FEATURES AND STANDARDS:

- Self-testing
- Battery: over temperature protection
- Low energy consumption CEC Title 20 compliant
- Constant output power
- High output voltage
- Listed to UL 924 and tested to CSA 22.2 NO. 141 field or factory installation
- UL listed for US and Canada

APPLICATION:

Suitable for the use with LED panels with an internal driver, including high-bay lights, commercial downlights, and other LED fixtures.

TESTED DATA:

- Model - E2-EMAFY40-170
- Emergency Power - 40W
- Input Voltage - 100-347Vac, 50/60Hz
- Input Current - 200mA max
- Input Power Rating - 12W max
- Output Voltage - 170Vdc
- Recharge Time - 24 hours
- Discharge Time - 90 minutes
- Battery - Li-ion
- Ambient Temperature - 0°C to 50°C (32°F to 122°F)
- Weight - 3lbs
- Warranty - 5 years limited

PRODUCT DIMENSIONS: 12.32" X 2.32" X 1.48"



Wiring Diagram Caution:

- During AC operation, do not touch or remove any wires in case of electric shock.
- During emergency operation, before disconnecting the wires, remember to press the test button again to make the LED lamp and indicator light turn off to avoid electric shock.
- The voltage input to the dimmable wires (DIM+, DIM-) of emergency LED driver must be less than 20Vdc.
- This model works best with LED lamps 400W or less.
- This emergency LED driver only works with LED lamps that have a dimmable function.

NORMAL: When the LED driver power is less than the emergency power.

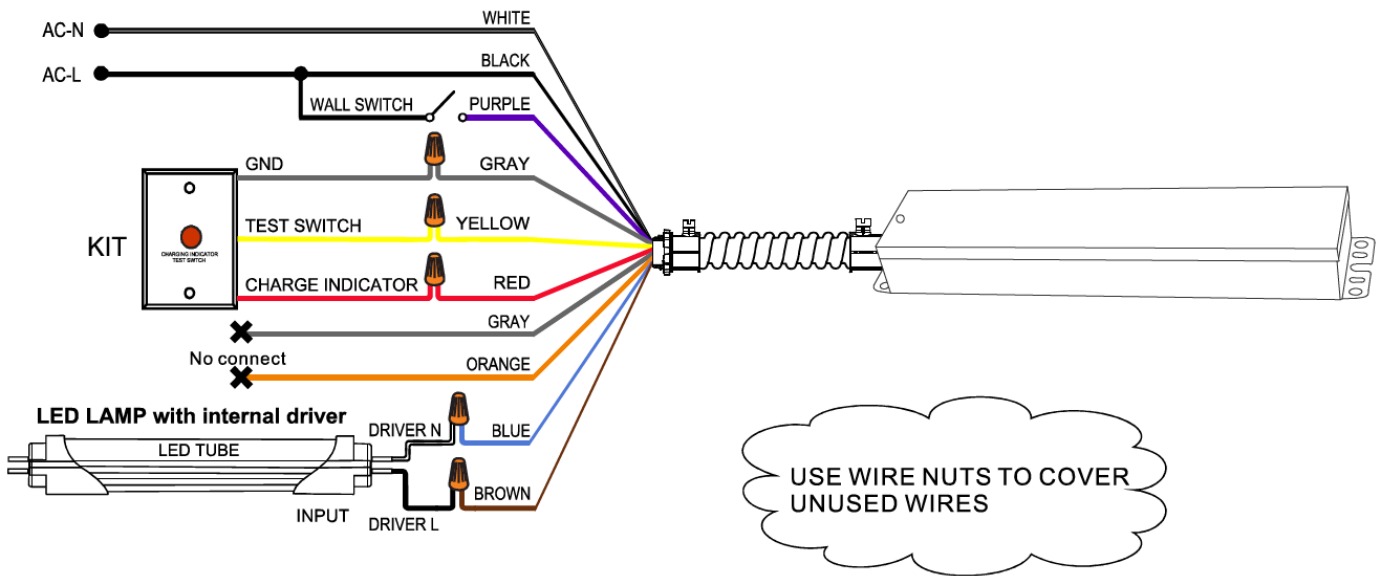

WITH DIMMER: When the LED driver power is more than the emergency power

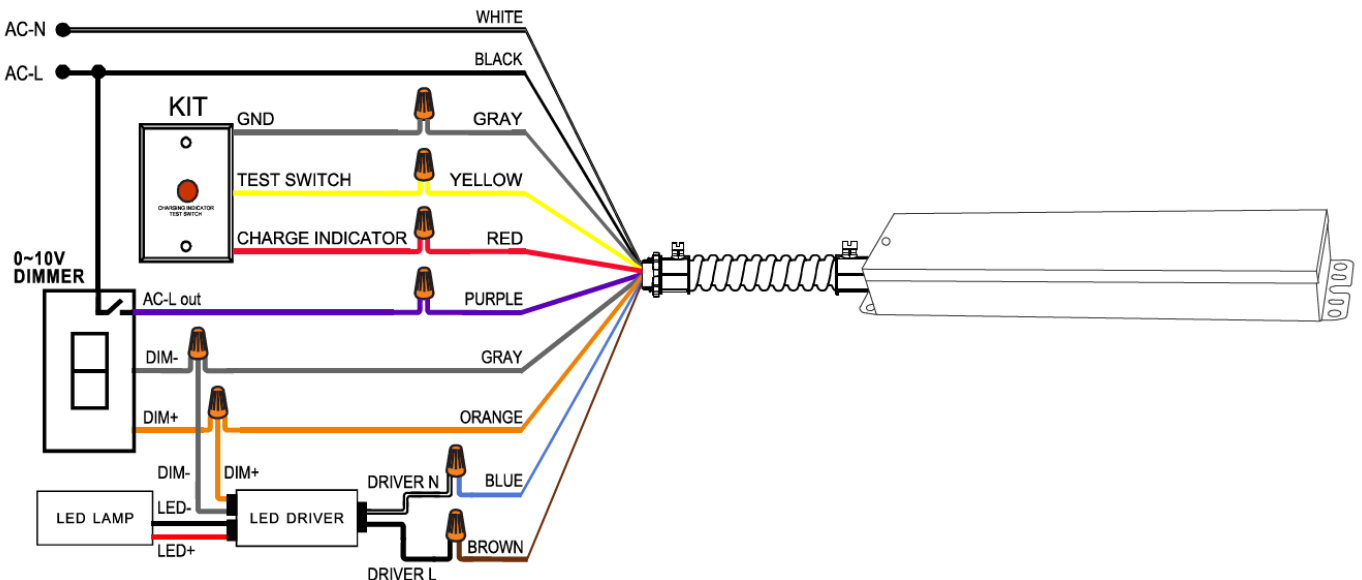

WITH WALL SWITCH:

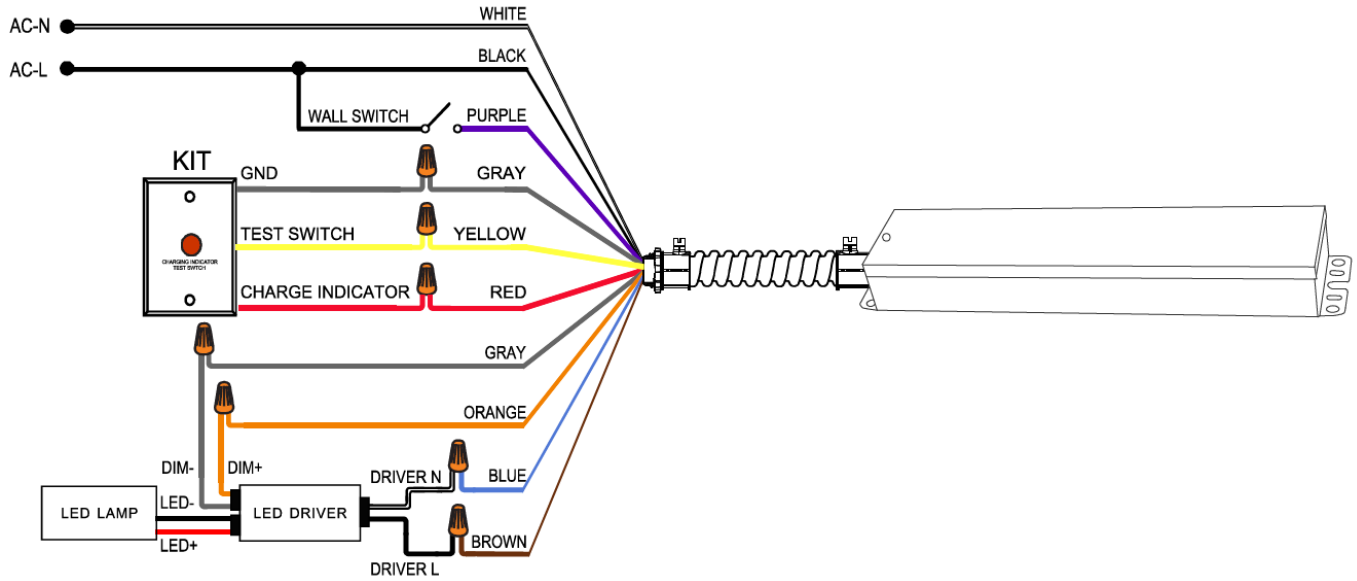

WITHOUT SWITCH OR DIMMER:

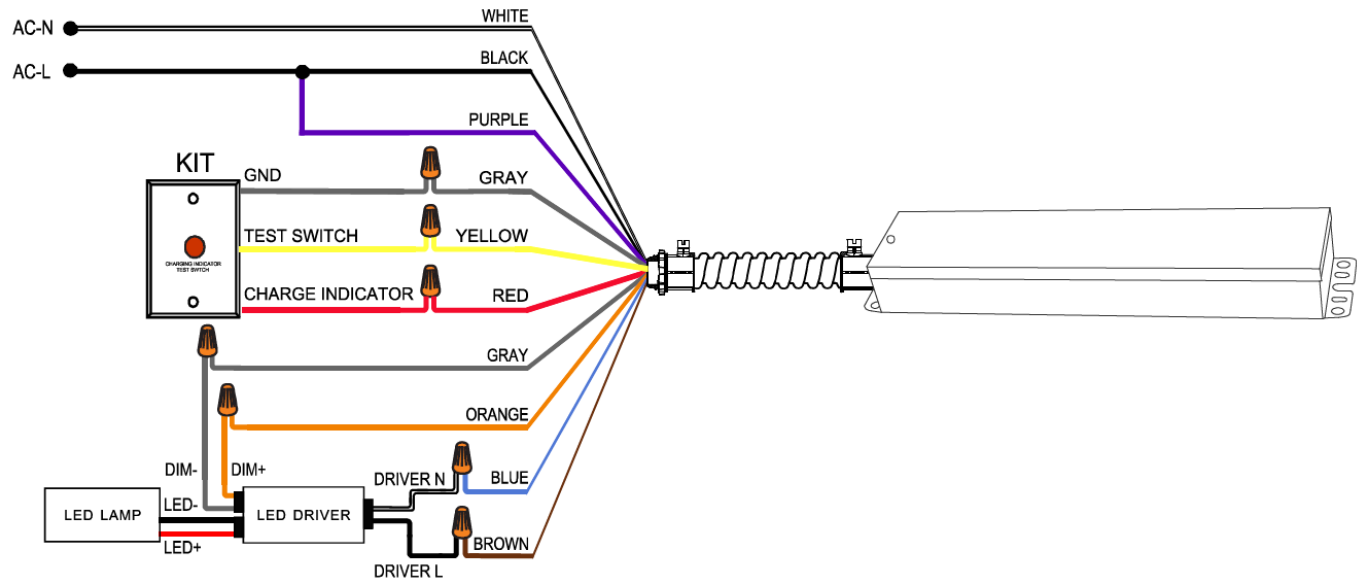

WITH SENSOR:

