

**LED Full Cutoff Wall Pack Light
E2-WPF-WP09-50/60/70/80W-30/40/50K**



Product Description

Wall pack light is a modern design light which combined tradition and fashion style. Two parts cast aluminum alloy housing with powder coat finish and a tempered glass lens, Fast heat dissipation and easy disassembly and assembly.

Features

1. High brightness SMD 135lmw
2. Isolated constant current led driver, the light work stably
3. Wattage selectable
4. Input Voltage: AC 120-277V/ 50-60Hz
5. 0 - 10V Dimmable
6. Housing color: Brown
7. Certificates: DLC(5.1) Premium UL/cUL
8. 5 years warranty

Physical Dimensions

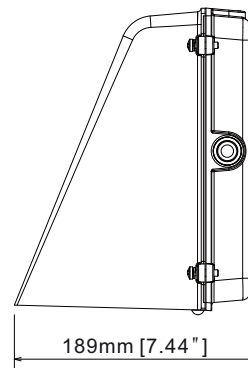
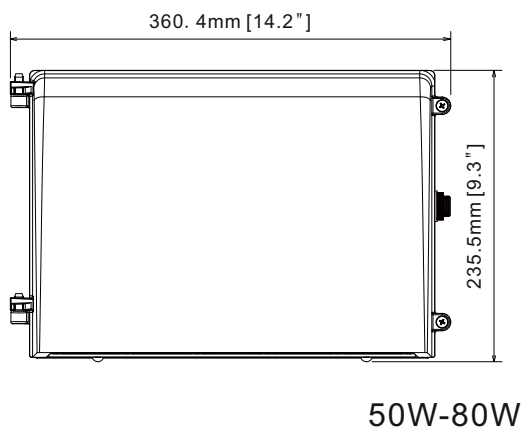

Addition Accessories



Photocell



Plug-in Zhaga Photocell Sensor



DIP Switch of 4 Watts Selectable function

Specifications

Product No.	E2-WPF-WP09-50/60/70/80W-30/40/50K
Wattage	50W - 60W - 70W - 80W tunable
Lumens	11200LM
Efficacy	140LM/W(±10%)
Input voltage	120-277VAC
CCT	3000K - 4000K -5000K tunable
THD	< 20%
LED Type	3030
Lens	PC
IP Rating	IP 65
Power Factor	≥0.90
Frequency	50/60Hz
Housing	IK 08 High-duty Die-cast Aluminum
Operating Temperature	-22°F to 113°F (-30°C to +45°C)
Finish	Bronze
Additional function	0-10V Dimmable, Photocell, 4 Watts Selectable
Life Time	L70 @ 54,000Hrs
Warranty	5 Years
Certificates	UL/cUL , DLC 5.1 Premium

Product Appearance

