

E2-BPL-DPS Series

CCT + WATTAGE ADJUSTABLE BACKLIT LED FLAT PANEL

Dual Selectable LED Panels are commercial luminaires utilizing advanced driver technology to provide an all in one luminaire, providing 3 wattages and 3 CCT options in each size panel. This provides superior lighting performance while minimizing inventory by reducing the amount of stocking SKUs. They achieve high uniformity, DLC PREMIUM energy efficiency and reduced glare in typical T-bar grid ceiling applications.

Our state-of-the-art backlit LED technology utilizes PMMA lensing over the LEDs which will not discolor over time. The need for a light guide is eliminated, thus increasing photometric performance while keeping costs competitive. Combined with the rigid back enclosure that prevents warping in application, this luminaire is designed for worry-free longevity and reliability. Available with factory installed battery backup for 90 minutes emergency egress illumination.



SPECIFICATIONS

CONSTRUCTION

- Aluminum frame in white finish, steel die-formed back enclosure

OPTICS

- PMMA lenses over LEDs, PS diffuser
- SDCM < 5
- UGR < 22
- 120° Beam angle

ELECTRICAL

- 0-10VDC Dimming (10%-100%)

CERTIFICATIONS

- UL Listed for Damp Locations
- IC Rated for insulated ceilings
- RoHS, FCC
- DLC 5.1 PREMIUM
- -20°C to 35°C (-4°F to 95°F)

WARRANTY

- 5 Year

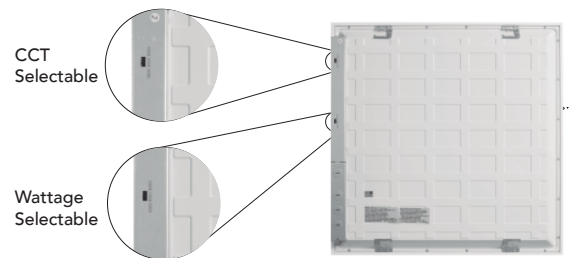

INSTALLATION

- Recessed in T-bar grid ceiling with integral earthquake clips for secure attachment
- Surface mount and suspension mount cable kit accessories available

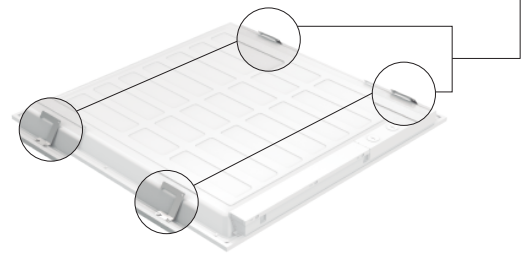

QUICKSHIP ORDERING INFORMATION

Model	Description	Weight	Qty/Carton	Qty/Pallet
E2-BPL-DPS-2X4-30/40/45W-35/40/50K	2x4 LED Flat panel, 30/40/45W adj, 3500/4000/5000K CCT adj, 120-277V, 0-10VDC dimming, DLC 5.1 PREMIUM	9.2 lbs	2	32
E2-BPL-DPS-2X2-18/24/30W-35/40/50K	2x2 LED Flat panel, 18/24/30W adj, 3500/4000/5000K CCT adj, 120-277V, 0-10VDC dimming, DLC 5.1 PREMIUM	5.2 lbs	2	72
E2-BPL-DPS-1X4-18/24/28W-35/40/50K	1x4 LED Flat panel, 18/24/28W adj, 3500/4000/5000K CCT adj, 120-277V, 0-10VDC dimming, DLC 5.1 PREMIUM	5.2 lbs	2	32

Note : **P1 models meet DLC 5.1 PREMIUM)

SPECS AT A GLANCE

Size	DPS24 (2X4)	DPS22 (2X2)		DPS14 (1X4)		
Wattage	30/40/45	-P1: 18/24/30	-P*: 20/30/36	-P1: 18/24/28	-P*: 20/30/40	
CCT	3500K/4000K/5000K		3500K/4000K/5000K		3500K/4000K/5000K	
Lumens	3825/5100/5738	-P1: 2295/3060/3825	-P*: 2550/3825/4590	-P1: 2295/3060/3570	-P*: 2550/3825/5100	
Efficacy (LPW)	127.5		127.5		127.5	
CRI	80					
Input Voltage	120-277VAC, 0-10VDC Dimming					
Certifications	DLC 5.1 PREMIUM*, UL, Damp Location, FCC, RoHS					
Operating Temp	-20°C to 35°C (-4°F to 95°F)					
Warranty	5 Years					

* Effective June 1, 2022, DLC PREMIUM qualification (5.0) becomes DLC Standard qualification (5.1) for -P 2x2 & 1x4 models (-P1 models meet DLC 5.1 PREMIUM)

MAKE-TO-ORDER ORDERING INFORMATION

DLC PREMIUM MODELS

EXAMPLE **DPS-22-U-P1**

SERIES	SIZE	INPUT VOLTAGE	DLC	OPTIONS	WATTAGE	CCT
DPS SERIES	24 = 2x4	H = 120-347V U = 120-277V	P = DLC 5.1 PREMIUM for 2x4, DLC 5.1 Standard for 2x2 and 1x4 P1 = DLC 5.1 PREMIUM for 2x2 and 1x4	EL = Emergency Backup	30/40/45	3500K 4000K 5000K
	22 = 2x2				20/30/36	
	14 = 1x4				20/30/40	

DIMENSIONS

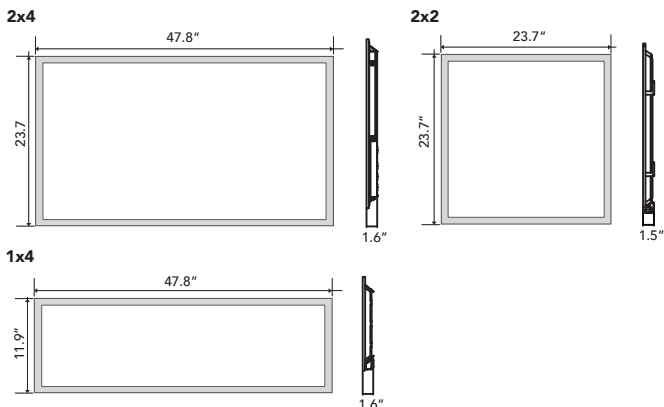

PHOTOMETRY

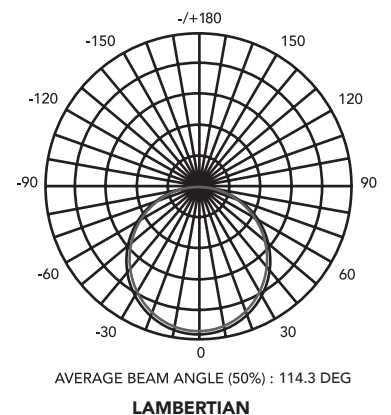

MOUNTING ACCESSORIES

SURFACE MOUNT KITS

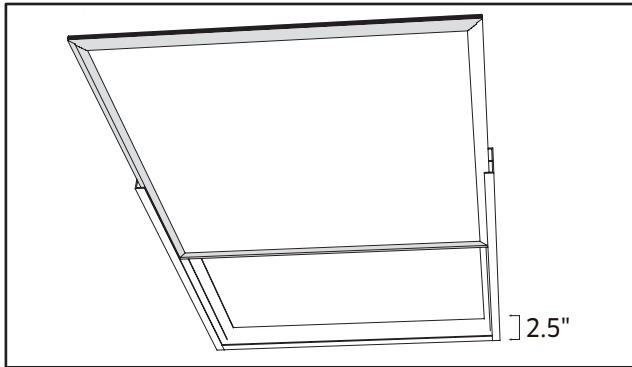

DPS-SMF-14-W 1x4 Surface Mount Kit, White

DPS-SMF-22-W 2x2 Surface Mount Kit, White

DPS-SMF-24-W 2x4 Surface Mount Kit, White

SUSPENSION CABLE MOUNT KITS

(Max. Adjustment Range: 3.9 Feet; Min. Adjustment Range: 0.6 Feet)

1X4 Kits

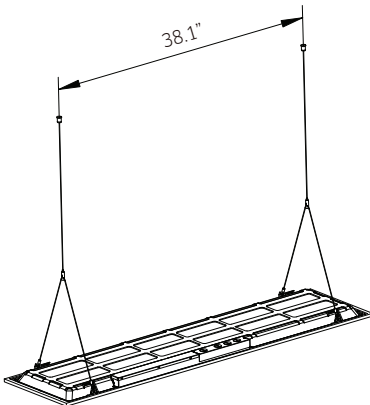

DPS-PKT-12-S 2-Cable Kit

2X2 Kits

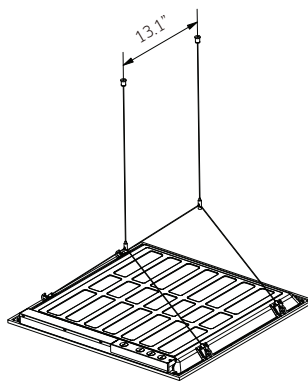

DPS-PKT-12-S 2-Cable Kit

2X4 Kits

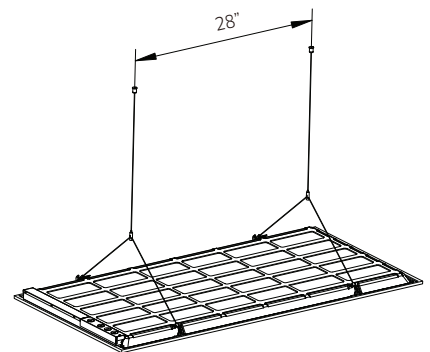

DPS-PKT-12-S 2-Cable Kit

1X4 Kits

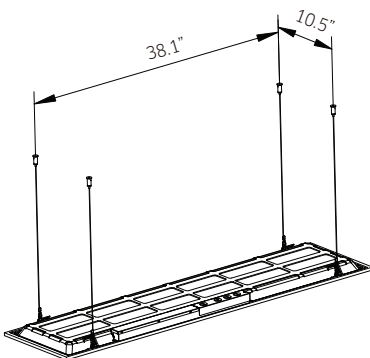

DPS-PKT-14-S 4-Cable Kit

2X2 Kits

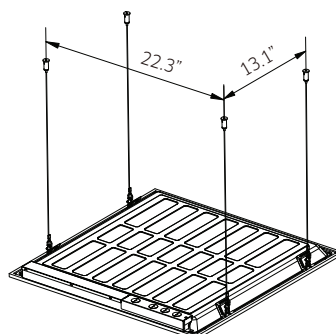

DPS-PKT-14-S 4-Cable Kit

2X4 Kits

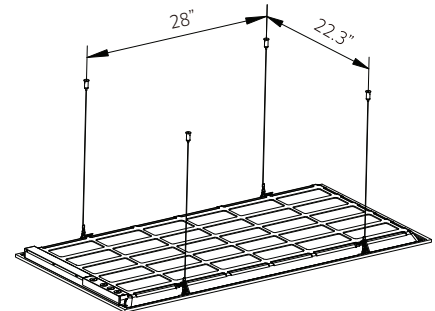

DPS-PKT-14-S 4-Cable Kit