

LED Tunable Panel Light

E2-PL-2x2-40W-L-H

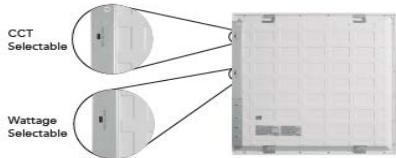
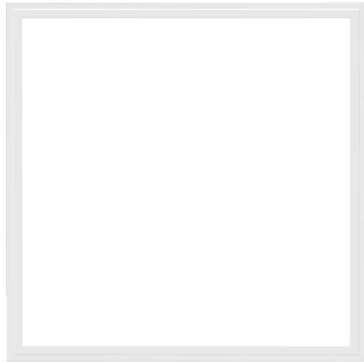

INSTALLATION

- Recessed in T-bar grid ceiling with integral earthquake clips for secure attachment
- Surface mount and suspension mount cable kit accessories available

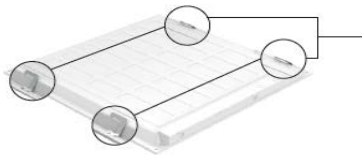

Dimension:

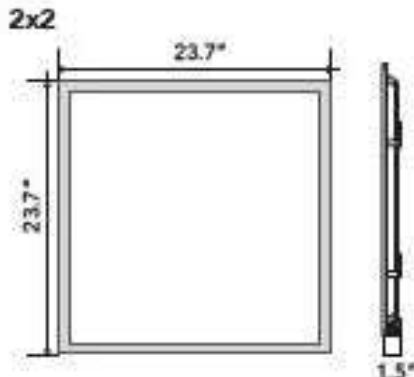

PRODUCT DESCRIPTION:

The E2 Lighting's LED Back lite panel lights are designed to lay in drop ceilings in offices, schools and healthcare applications. The flat panels are available in dimming and non-dimming options and are compatible with building controls, motion sensors, timers and daylight harvesting systems. The unique design of the panels produces side-emitting illumination with high transmittance LGP to achieve even, consistent shadowless light. UL classified/recognized, UL listed, DLC Premium listed and RoHs compliant.

FEATURES:

- Simple, chic and elegant appearance and non-
- discoloring Greater than 80% energy savings compared to traditional grid fixtures
- Instant startup, perfect light uniformity, soft light, no glare, no noise, no strobe
- 50,000 Hours L70 Lifespan
- UL and DLC® Premium 5.1

APPLICATION:

- 2X2 Luminaires for Ambient Lighting of Interior Commercial Spaces
- Widely used in Office Buildings, Plants, Schools, Supermarkets, Hotels, Meeting Rooms, Exhibition Halls, Underground Garages and all other environments in need of High Energy Savings and High CRI

TESTED DATA:

- Technical requirements Version: 5.1
- Classification: DLC Premium
- Light Output: 2,500, 3,125, 3,750, 4,375, 5000lm
- Wattage: 20/25/30/35/40W
- Efficacy: 125Lm/W
- Power Factor: 0.92
- CCT: 3000/3500/4000/5000/6500K
- Input Voltage: AC120-277V
- Working Environment: -4°F-122°F
- Dimming Compatible: 0-10V dimming
- Lens: Polycarbonate
- Net Weight: 6lbs

WARRANTY:

E2 warrants that our LED products will be free from defects in materials and workmanship for a period of five (5) years from the date of delivery to the end user, including coverage of light output, color stability, driver performance and fixture finish. Please see our complete warranty terms located at www.e2lightingusa.com.